

iTronic SAT Install Notes

For use with the iTronic SAT range of products
for BMW & Mercedes vehicles.

Version 1.0

Table of Contents

Common Install Notes.....	3
iTronic Wiring Connection.....	4
XMD1000 Kit.....	7
Audio Connection.....	7
Communication Connection.....	7
XMD1000 Power Connector.....	7
Installation Location.....	7
XMD1000 Operating Use.....	8
Bypass Switch.....	8
Trouble Shooting.....	9

Common Install Notes



Important Items ATTENTION



1. **Never bend fiber optic lines sharply (acutely) or at more than about 2" radius or permanent damage may result to the fiber.**
2. **Battery power (+) to the unit must be fused by a value of 5A.** On a 10A circuit or the radio's circuit is acceptable (safe, OK).
3. **Power to iTronic must be constant battery (B+).** It cannot be from a vehicle power plug. Vehicle power plug is not consistently constant power, despite appearances or first apparent behavior. Best location to source power is at the Head Unit's own power or CD changer's power wire.
4. **Power to XMD1000 must be constant battery (B+).** It cannot be from a vehicle power plug. Vehicle power plug is not consistently constant power, despite appearances or first apparent behavior. Best location to source power is at the Head Unit's own power or CD changer's power wire.
5. **If vehicle is intended to be serviced (diagnosed) by the dealer, bypass switch should be put into the ON mode.** It is not plug and play (vehicle power cycle must be done / complete sleep/wake cycle in order to properly initialize MOST bus in iTronic's bypass / non-bypass mode. Bypass mode can be activated by toggling the bypass switch 5-6 times in a five second window. The MOST bus will be broken for two seconds.
6. **MOST bus is not hot "plug and play".** Do not expect system to immediately work after plugging in units and turning on vehicle. If any MOST pieces have been unplugged or disturbed, the vehicle must go to sleep and awake to

resume operation.

- BMW Vehicles require coding. CarTronics can only supply limited support in the area of coding BMWs, and will not refund if the iTronic unit cannot be fitted due to an inability to code the vehicle.** For further information on the coding of BMWs please refer to the [Autologic web site](#).

iTronic Wiring Connection

The iTronic main power connector contains the optical fiber input as well as a 4 pin wiring insert. This 4 pin wiring insert, if inspected closely, has numbering on the pins. Although both the BMW and iTronic share the same connector as the BMW CDC and Sat Radio wiring, the pinning is slightly different. If the user tries to plug the connector directly in without changing the BMW plug wiring into the iTronic unit, the user will burn a fuse out in the vehicle. The BMW factory wiring needs to have pins 1 & 2 swapped to be compatible with the iTronic.

For Mercedes vehicles the factory Sat Radio connector has the same pinning as the iTronic interface. There is no need to change this wiring around.

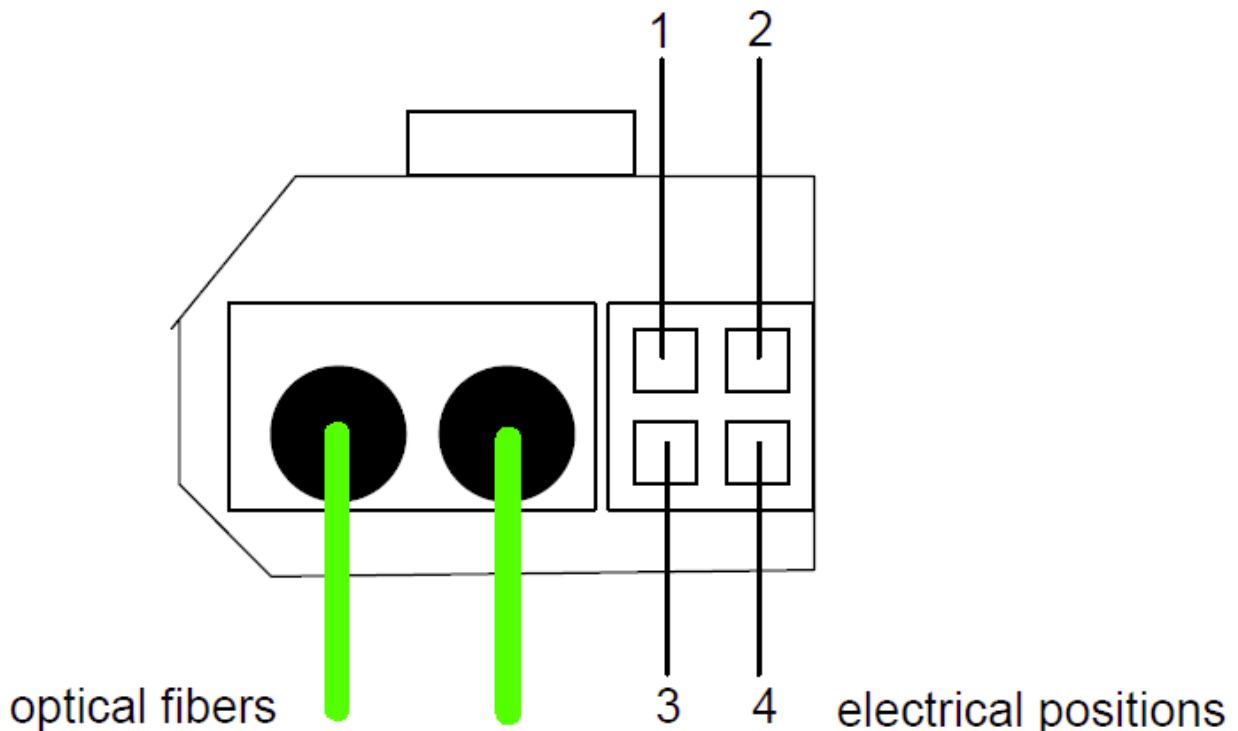

The iTronic units always have pin 1 as ground and pin 2 is always constant 12V supply. This view is from the back (wire side) of the connector.

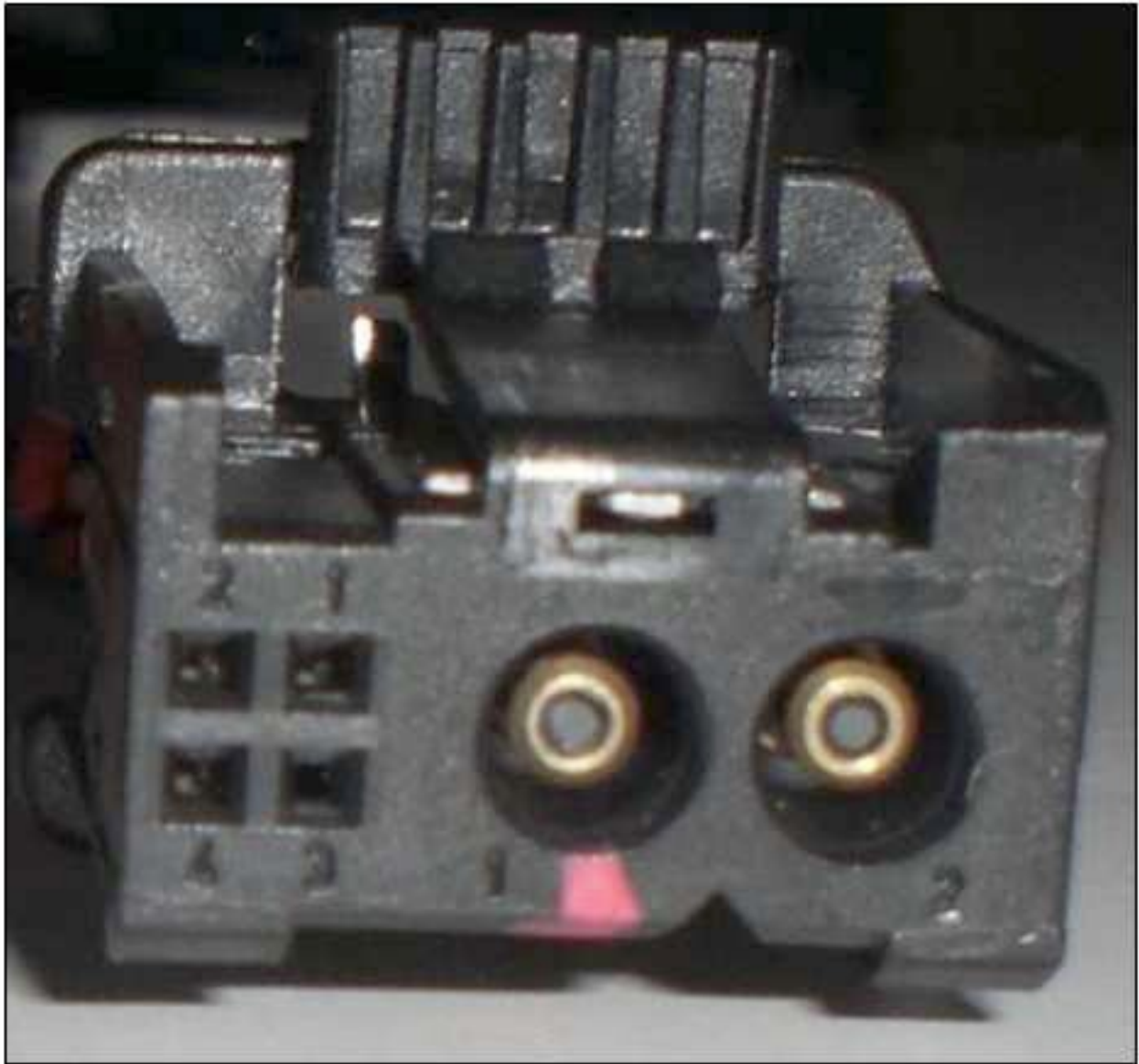

This picture clearly demonstrates the pin numbering visible on the outside of the connector.



This is the rear view of the fully assembled connector. Note the brown ground wire is in position 1 and the orange 12V wire is in position 2.

XMD1000 Kit

The iTronic SAT kit contains the following pieces:

- 1) iTronic SAT unit configured for use for Sat Radio
- 2) iTronic power wiring harness
- 3) MOST optical fiber loom patch harness
- 4) 8 pin mini DIN to 8 pin mini DIN extension cable
- 5) 2x RCA audio cable to 3.5mm audio jack
- 6) iTronic XMD1000 dongle
- 7) optional XMD1000 Tuner

Audio Connection

Audio is connected from the XMD1000 receiver from the 2x RCA audio jacks through to the iTronic unit via the 3.5mm audio jack that plugs into the iTronic interface at the auxiliary audio jack.

Communication Connection

The communication connection to the XMD1000 receiver is via the 8 pin mini DIN extension cable and a special iTronic dongle cable that contains a small amount of necessary electronics in order to communicate with the iTronic device. The connections are easily recognizable. The large 20 pin rectangle connector plugs into the 'MP3 Player' power on the iTronic unit. The other end of this dongle cable contains an 8 pin mini DIN plug that the extension cable is connected to and from here this plugs into the XMD1000 receiver. Once the dongle cable and mini DIN cable are in place, communications with the XMD1000 receiver can be established. The DIN cable plugs are keyed so please do not force the connection otherwise damage may occur.

XMD1000 Power Connector

The final piece of the wiring that needs to be connected for the XMD1000 receiver to power up is the orange wire from the dongle itself. This is required to be wired to permanent power. DO not worry as you cannot flatten the battery. The control of this wire is done via the iTronic interface power circuit that is only awake when the optical fiber ring is in operation. Once the optical fiber ring has slept then it is impossible to still be powering the XMD1000 receiver.

An easy wiring location for this wire is the same wiring location as the iTronic interface permanent power wire also. This can be taken directly from either the BMW or Mercedes Factory plugs

The iTronic SAT dongle contains a single orange wire the needs to be wired to permanent 12V power, and this can be sourced from the same permanent power as the iTronic SAT interface is wired to.

Installation Location

You can install the iTronic SAT unit anywhere on the network in most cases. The factory location for most vehicles is in the trunk of sedans or under one of the seats in SUV/Trucks. Some vehicles may

already have a SAT antenna. You can use this antenna (you may need adapters for the physical connection, available locally). Otherwise, an antenna is included for your use.



XMD1000 Operating Use

Upon first power up, the XMD1000 receiver will require that it needs to sync with the network to acquire all network channels and categories. Upon a subsequent power down and sleep mode, the channels will be stored so the next power of the unit, all channels will be in sync with the system. Once the unit is up and running, the head unit of the vehicle will display the list of channels and categories as well as the playing song artist and title (so long as the factory interface supports these two features of artist and title). It is now possible to browse the complete XM channel listing. The functionality of the XM will be exactly the same as the factory Sirius control. Please refer to your vehicle specific user guide on Sirius control.

Bypass Switch

The bypass switch is provided to allow for the iTronic unit to become 'invisible' on the MOST vehicle bus system. The main use of this function is to facilitate dealer services when the diagnostic computer is in use and to ensure the iTronic unit does not interfere with the vehicle diagnostics. The function can be enabled by toggling this switch 5 times. Once the bypass feature has been

activated, the MOST bus will be broken for 2 seconds and the feature cannot be activated again for a further 10 seconds.

Once the bypass switch has been activated, it will remain activated across power cycles until the bypass is de-activated by toggling the switch again 5 times within a 5 second time frame.

Trouble Shooting

Upon first install it is advisable to let the entire car go to 'sleep' for 10 minutes and recover gracefully. Optical fiber equipped vehicles do not take to kindly to installs without a graceful startup.

Q) The Head Unit no longer wakes up?

A) Double check the optical connections.

If the head unit can not see the entire loop being completed with light, then the head unit is likely to turn itself off as it has a problem. See if there is light coming into the iTronic connector and check the arrow on top of the connector itself and make sure light is traveling in the correct direction.

Q) I've installed the unit, the optical ring is working but the unit does not appear in the head unit?

A) Vehicle may need coding.

BMW vehicle in particular require coding to enable options such as the CD changer and Sat radio interfaces. Mercedes does not require coding for the Sat Radio. Also double check the bypass mode switch.

Q) The XM connection causes erratic wakeup on startup?

A) The iTronic interface is not wired to permanent power.

Check the wiring connection. This needs to be permanent power.

Q) I cannot browse the XM interface?

A) Please refer to the vehicle specific user manual